



A TEREX BRAND

Disc Chipper

754 Disc Chipper

Features

- Specifically designed to work in unison with the CBI Flail 604 either in wheel or track-mounted version. Heavy-duty track frame with fifth wheel plate hookup allows for B-train connection with Flail
- Trash separator discharges on opposite side of chip discharge allowing trailer and chip system to be parallel
- 75" diameter 4-knife chipper disc with babbited or Key Knife system
- Large 26" feed opening designed to accept larger diameter trees
- Complete chipper hood opens hydraulically for ease of service
- All bolt-in wear liners
- CAT C-27; 1050 hp engine



Description

CBI's Magnum Force Disc Chipper 754 adds to our line of the most productive and reliable portable chippers in the world. It is capable of producing high-quality wood chips from 3/8"– 1" for the pulp and paper industry at up to 200 tons per hour. CBI's DC 754 is specifically designed to work in unison with the CBI Flail 604 either as a wheel-mounted or track-mounted unit. The track-mounted unit comes with a heavy-duty track frame and a retractable fifth wheel stinger. This allows operators to quickly connect the CBI Flail to the Disc Chipper and quickly move them down the logging road, saving set-up time and skidder distance. The 75" diameter 4-knife chipper disc is provided by Fulghum Industries, Inc., and delivers the most uniform chip thickness and chip length.

Feed System

Providing a continuous positive feed, the top feed roll is equipped with a high-torque Poclairn internal drive and the bottom feed roll is equipped with a high-torque Brevini planetary drive, both designed for extended life and reduced maintenance.

Chipper Disc

The trash separator on the DC 754 discharges on the opposite side of the chip discharge, which allows for convenient side-by-side processing especially while chipping on road sides. The discharge chute folds hydraulically for transport and multi-angular chute work provides for the most effective chip trailer loading. The complete chipper hood also opens hydraulically for easier servicing. The complete chipper housing is protected by bolt-in wear liners.

Machine Controls

The DC 754 is equipped with a 1050 hp, CAT C-27 engine and comes with a PT Tech 15 PTO hydraulic clutch. Access to the engine from both sides simplifies maintenance. Additional features include an extra large AKG radiator for dusty and high ambient temperature operations, Flexaire auto-reversible fan, Donaldson air filtering system with Enginaire pre-cleaners, fire suppression (optional), emergency shutdown, and all-weather electrical control enclosures.

The hydraulic system incorporates hydrostatic pumps for the feed system and tracks. The control system by Parker IQAN provides increased monitoring and protection. Radio remote control with full mechanical backup runs all functions of the chipper.



Specifications

| | |
|-------------------------|--|
| Overall | |
| Length | 34' 8" |
| Width | 11' |
| Height | 13' 1" |
| Weight | Approx. 94,500 lb. |
| Chipper Disc | |
| | 75" 4-knife babbitted or Key Knife Adjustable and easily replaceable anvils, upper and lower |
| Top Feed Roll | |
| Width | 48" |
| Diameter | 30" |
| Motor | Built-in high-torque Poclairn |
| Bottom Feed Roll | |
| Width | 48" |
| Diameter | 13" |
| Motor | High-torque Brevini planetary with Char-Lynn hydraulic motor |
| Throughput | |
| | Up to 200 tons/hour |

| | |
|------------------------|---|
| Power | |
| Engine | CAT C27; 1050 hp |
| Drive | Arimid V-belt |
| Flexaire * Fan | Reversing pitch radiator fan that reverses airflow every 5-15 minutes automatically (adjustable) |
| Fuel Tank | |
| Capacity | 375 gallons |
| Electrical | |
| | IQAN™ system with full radio remote control Optional wireless camera on chip chute for monitoring trailer loading |
| Tracks | |
| | Berco D-7 HD or optional D-5 (if unit is not going to tow flail) |
| Air Compressor | |
| | 13 hp gas engine, 60' hose |
| Water Tank/Pump | |
| | 165 gallon tank with 5 hp gas powered pump |

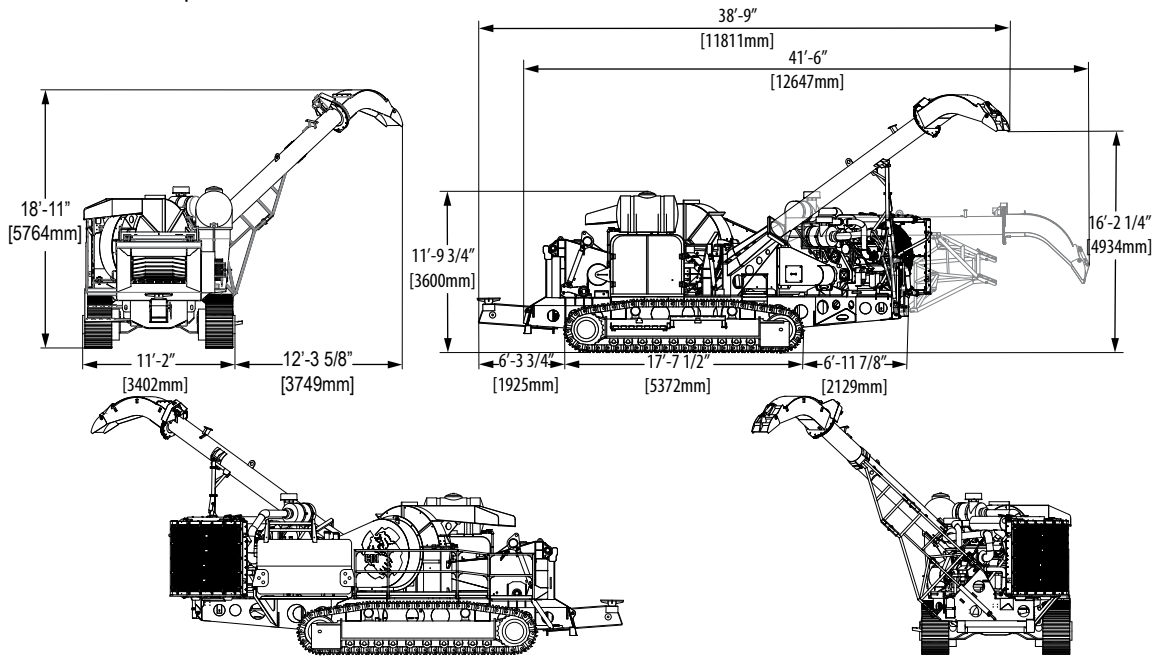

Retractable Tow Stinger

Rugged Work Light Packages

Remote Observation Cameras

Water Pump / Air Compressor

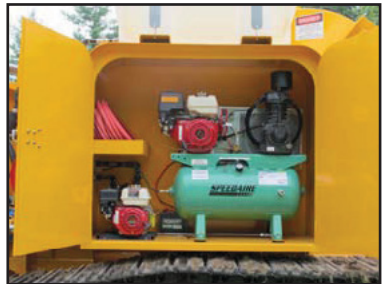
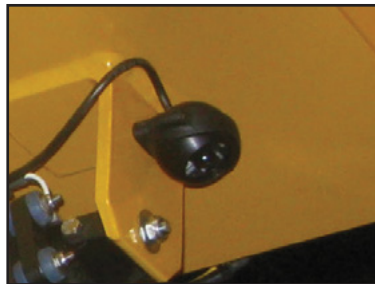

The CBI difference: Fuel the Future.™
Continental Biomass Industries

World's Best Stationary and Portable Material Recovery Systems

22 Whittier Street, Newton, NH 03858

Phone: 603-382-0556 Fax: 603-382-0557

Web: cbi-inc.com Email: info@cbi-inc.com

Distributed by: