

CEDARAPIDS®

A TEREX BRAND

Portable Cone
Plant

CRC320

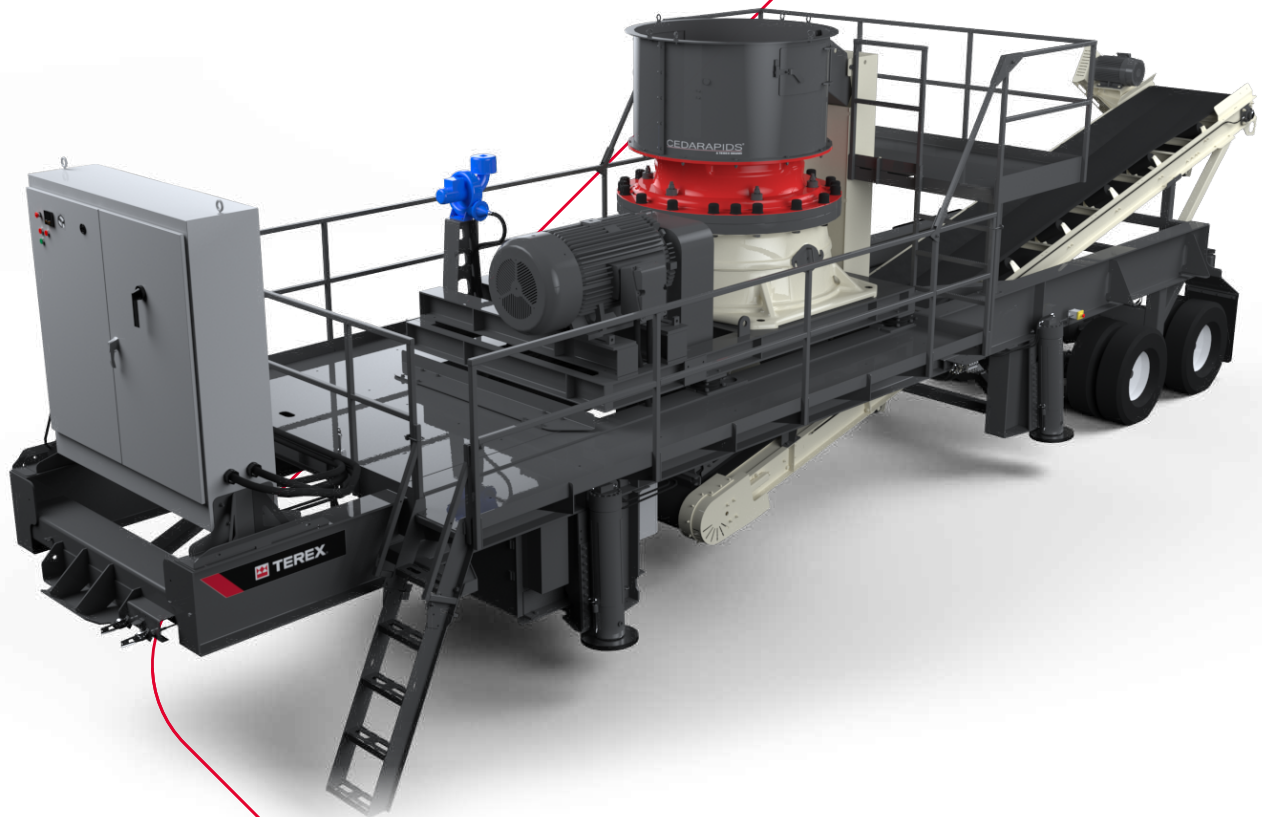

A world working better™

 **TEREX**® MPS

Cedarapids® Portable Plants

CRC320 Portable Cone Plant

Exceptional Productivity and Application Adaptability

The CRC320 Portable Cone Plant features the TG320 cone with a large feed opening. The all electric plant fits a variety of layouts and applications and is designed for easy transport on the road or on site. Service platforms with wide walkways allow easy and safe access for maintenance and inspection. The bronze bushing technology of the TG320 cone enables the operator to quickly and easily alter the eccentric throw of the cone, on site, simply by rotating the eccentric bushing.

Standard Features

- TG320 bronze bushing cone with adjustable eccentric throw and multiple liners matches most any application
- 300 hp (224 kW) 1800 rpm crusher motor and drive mounted with crusher on rubber isolated frame
- Oversize cone feeder hopper extension with removable overflow panel and overflow chute
- 42" x 34'6" (1067 x 10,515 mm), 3-ply conveyor belt with vulcanized belt splice and primary style belt wiper driven by a 15 hp (11kW) electric motor and shaft mount gearbox
- Service platforms with elevated observation deck, guard rails and access ladder
- Easy maintenance features:
 - o remote grease lines
 - o ground access cone lubrication module
- Emergency stop buttons on both sides of frame
- Tandem axle spring suspension with eight 295/75 R22.5 tires
- 48" (1219 mm) long lockable side-mounted storage box

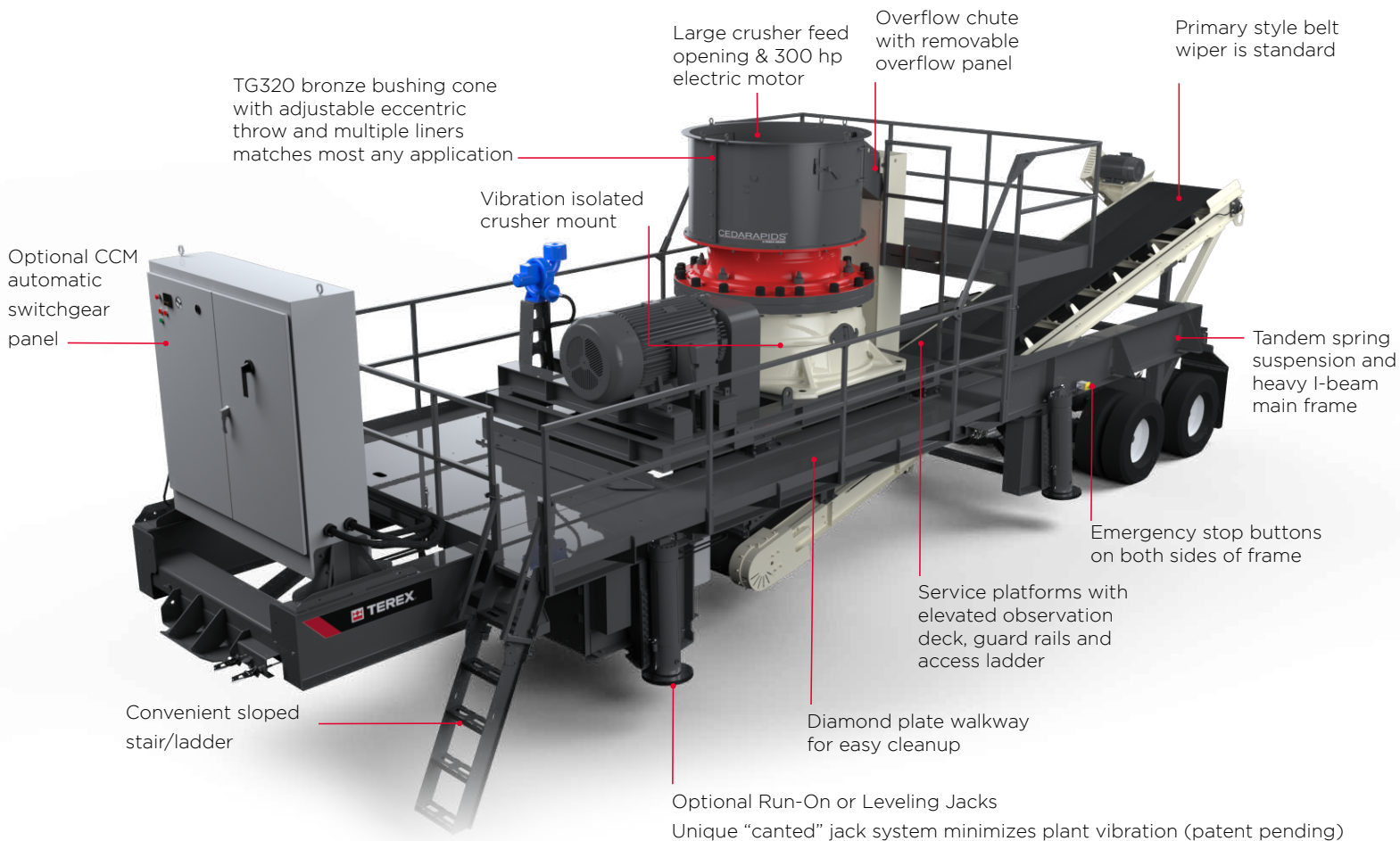

Optional Equipment

- Removable CCM™ automatic switchgear panel
- Four 18" stroke leveling jacks
- Four 24" stroke run-on jacks
- Hydraulic Power Unit (Gas, 12V, 24V)

Transport Dimensions

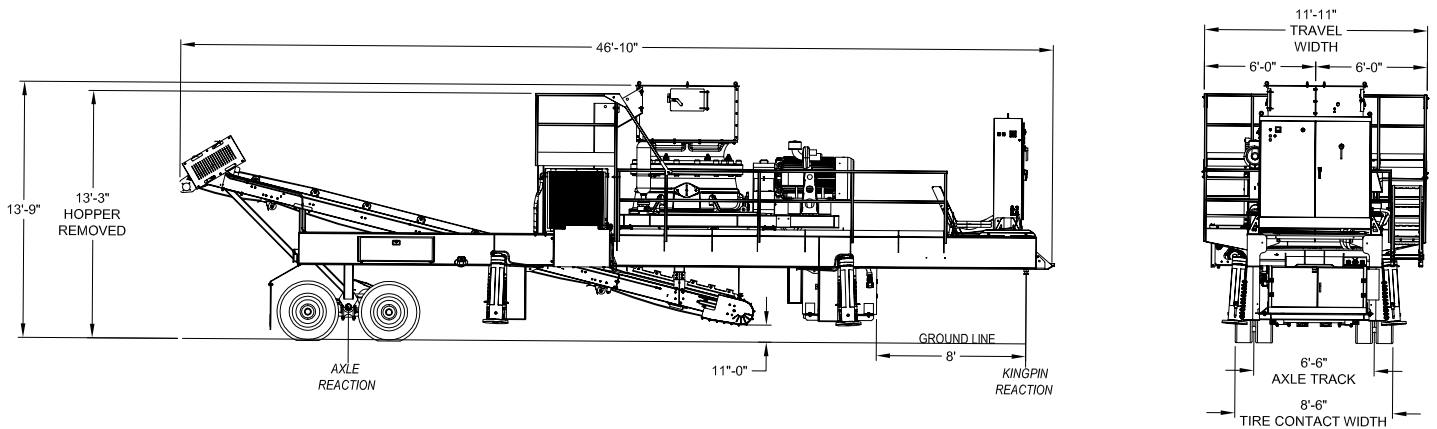

Working Dimensions

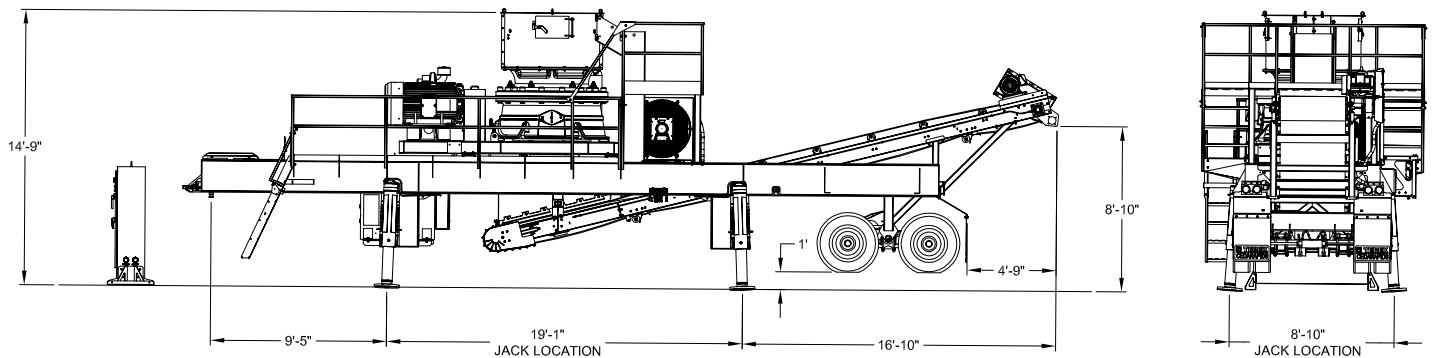

	Kingpin Weights	Axle Weights	Total Weights
Base Plant plus optional electric power panel and 4 run-on jacks	37,100 lb	38,550 lb	75,650 lb

Note:

- Standard tires 295/75R22.5 (315/85R22.5 optional)
- spring applied brakes
- 2" king pin dia

Weights and dimensions are calculated values and are subject to change.

Please consult bill of lading for actual shipping weights and dimensions.

Weights shown do not guarantee legal shipping weights and dimensions in all locations.

Please consult local and state regulations for legal shipping weights and dimensions.

North America

3900 Fountains Blvd. NE
Suite 101
Cedar Rapids, IA 52411
Tel: +1 319 363 3511 or +1 800 821 5600
Fax: +1 319 399 4871

212 South Oak Street
Durand, MI 48429
Tel: +1 989 288 3121 or +1 888 571 8352
Fax: +1 989 288 4113

www.terexmps.com

Product specifications and prices are subject to change without notice or obligation. The photographs and/or drawings in this document are for illustrative purposes only. Refer to the appropriate Operator's Manual for instructions on the proper use of this equipment.

Failure to follow the appropriate Operator's Manual when using our equipment or failure to act responsibly may result in serious injury or death.

The only warranty applicable to our equipment is the standard written warranty applicable to the particular product and sale, and Terex makes no other warranty, express or implied. Terex, the Terex Crown design, Cedarapids, Canica, Simplicity, Jaques, El-Jay and Rollercone are trademarks of Terex Corporation or its subsidiaries. All rights are reserved. © May 2020

